

Platform lowlifter truck 2.0 ton

BT levio

B-series

LPE200B



Platform lowlifter

Specification for lowlifter trucks					LPE200B
Identification	1.1	Manufacturer			Toyota
	1.2	Model			LPE200B
	1.3	Drive			Electric
	1.4	Operator type			Stand on/pedestrian
	1.5	Load capacity/rated load	Q	kg	2000
	1.6	Load centre	c	mm	600
	1.8	Load distance, centre of support arm wheel to face of fork, fork raised/lowered	x	mm	913/957
	1.9	Wheelbase, fork raised/lowered	y	mm	1362/1406
Weight	2.1	Service weight with battery		kg	681
	2.2	Axle load, with load, drive/castor/fork wheel		kg	450/604/1627
	2.3	Axle load, without load, drive/castor/fork wheel		kg	450/102/129
Wheels	3.1	Drive/castor/fork wheel			Polyurethane*
	3.2	Wheel size, front		mm	Ø 230x70
	3.3	Wheel size, rear		mm	Ø 85x95
	3.4	Additional wheels (dimensions)		mm	Ø 125x50
	3.5	Wheels, number front/rear (x = driven wheels)			1x+ 2/2 or 4
	3.6	Track width, front	b ₁₀	mm	500
	3.7	Track width, rear	b ₁₁	mm	370
Dimensions	4.4	Lift	h ₃	mm	120 ¹⁾
		Lift height	h ₂₃	mm	205 ¹⁾
	4.8	Stand height	h ₇	mm	190
	4.9	Height of tiller in drive position, min./max.			
		Manual steering	h ₁₄	mm	1100/1413
		Power steering	h ₁₄	mm	1101/1313
	4.15	Height, fork lowered	h ₁₃	mm	85
	4.19	Overall length	l ₁	mm	1816
	4.20	Length to face of forks	l ₂	mm	666
	4.21	Overall width	b ₁	mm	730
	4.22	Fork dimensions	s/e/l	mm	78/180/1150
	4.25	Width over forks	b ₃	mm	550*
	4.32	Ground clearance, centre of wheelbase	m ₂	mm	30
4.33	Aisle width for pallets 1000x1200 crossways	A _{st}	mm	2430	
4.34	Aisle width for pallets 800x1200 lengthways	A _{st}	mm	2277	
4.35	Turning radius, fork raised	W _a	mm	1585	
Performance data	5.1	Travel speed, with/without load		km/h	6/6 or 6/7,5
	5.2	Lift speed, with/without load		m/s	0,037/0,052
	5.3	Lowering speed, with/without load		m/s	0,051/0,047
	5.8	Max. gradeability, with/without load ²⁾		%	5/10
	5.9	Acceleration time (over 10 m)		s	5,7
	5.10	Service brake			Electromagnetic
Electric motor	6.1	Drive motor rating S2 60 min		kW	1,8
	6.2	Lift motor rating at S3 10%		kW	1
	6.4	Battery voltage/nominal capacity K ₅		V/Ah	24/225*
	6.5	Battery weight		kg	222
	6.6	Energy consumption acc. to VDI cycle		kWh/h	0,35
	6.7	Turnover output		t/h	135
	6.8	Energy consumption at turnover output		kWh	0,85
	Others	8.1	Type of drive control		
8.4		Sound level at the driver's ear according to EN 12 053		dB(A)	65

1) +20 mm for roll container handling.

*) Further alternatives are available and will produce other values.

All data are based on table configuration. Other configurations may give other values.

Truck performance and dimensions are nominal and subject to tolerances.

Toyota Material Handling Manufacturing Sweden AB products and specifications are subject to change without notice.

Battery dependent dimensions

Dimensions		Battery change		Lift out
		Compartment		Small
1.9	Wheelbase, fork raised/lowered	y	mm	1362/1406
4.19	Overall length with platform up/down	l_1	mm	1816/2266
4.20	Length to face of forks with platform up/down	l_2	mm	666/1116
4.33	Aisle width for pallets 1000x1200 crossways with platform up/down	A_{st}	mm	2430/2894
4.34	Aisle width for pallets 800x1200 lengthways with platform up/down	A_{st}	mm	2277/2741
4.35	Turning radius, fork raised with platform up/down	W_a	mm	1585/2049
6.4	Battery voltage, nominal capacity K_s		V/Ah	24/225-300
6.5	Battery weight		kg	210-285

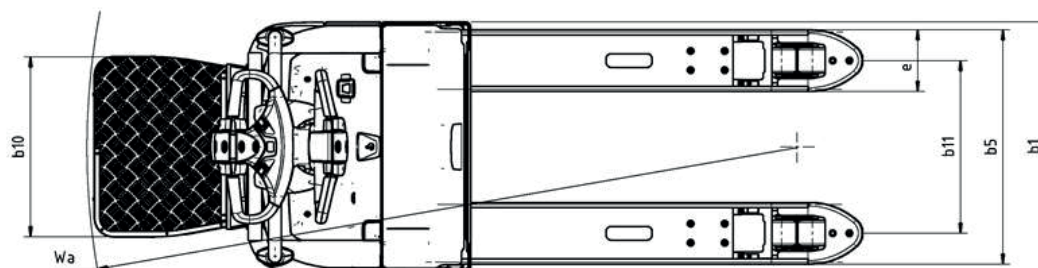
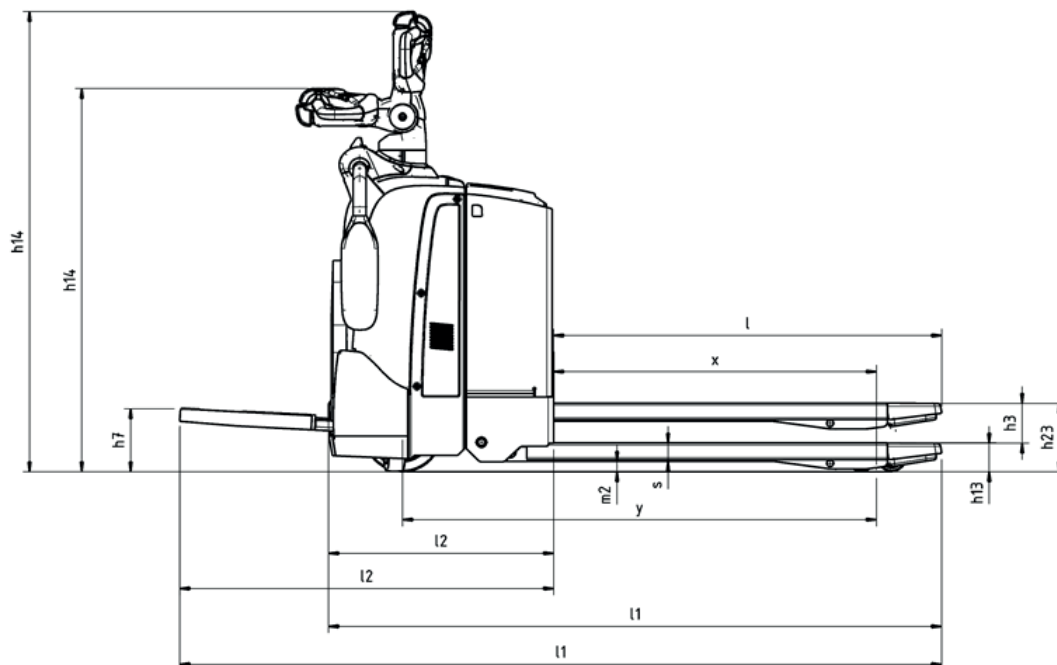

Truck features:

- Fingertip controls
- Information display
- Electronic braking system
- Electronic regenerative brakes
- Driver detection system
- Ergonomic platform
- E-bar (option)
- Foldable gates

